

6	O-RING	VITON
5	BUSHING	PTFE
4	STEM	SS410
3	SEAT	PTFE
2	DISC	CF8M+PTFE
1	BODY	Ductile Iron
NO.	PARTS NAME	MATERIAL
TEST PRESSURE	SHELL	SEAL
	HYDROSTATIC 150PSI	110PSI
STANDARD	DESIGN CODE	API 609
	INSPECTION & TEST	API598
	END STANDARD	ANSI B16.1

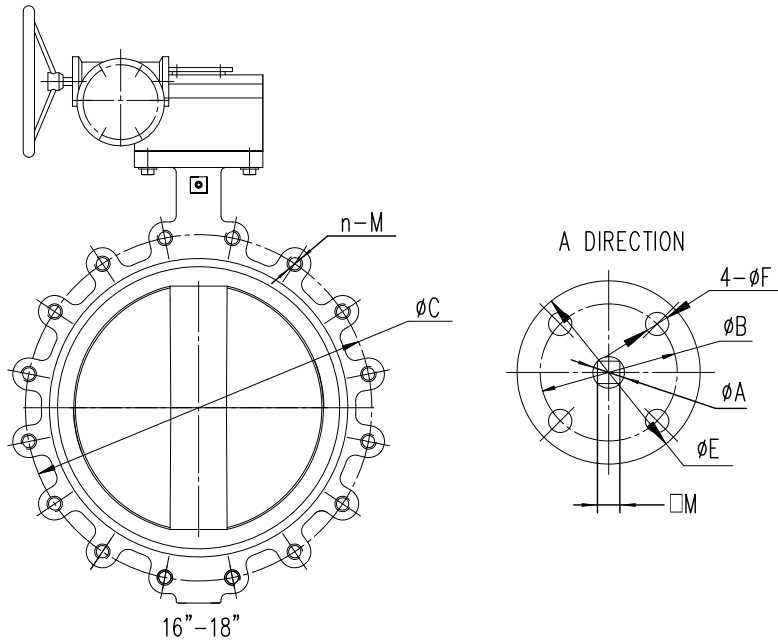

INCH	H1	H2	H3	L	φA	φE	φB	φF	□M	φC	n-M	CV Value
1.5"	66	110	30	35	12.7	90	70	10.5	9	98.5	4-1/2"-13	76
2"	76	162	30	46	12.7	90	70	10.5	9	120.5	4-5/8"-11	135
2.5"	80	175	30	49	12.7	90	70	10.5	9	139.5	4-5/8"-11	220
3"	95	181	30	49	12.7	90	70	10.5	9	152.5	4-5/8"-11	302
4"	114	200	30	55	15.8	90	70	10.5	11	190.5	8-5/8"-11	600
5"	127	213	30	59	19.05	90	70	10.5	14	216	8-3/4"-10	1022
6"	140	225	30	59	19.05	90	70	10.5	14	241.5	8-3/4"-10	1579
8"	173	260	36	64	22.2	125	102	12.5	17	298.5	8-3/4"-10	3136
10"	203	292	36	71.5	28.6	125	102	12.5	22	362	12-7/8"-9	5340
12"	237	337	36	81	31.8	125	102	12.5	22	432	12-7/8"-9	8250
14"	280	368	45	79.5	31.8	125	102	12.5	22	476	12-1"-8	11917
16"	304	400	51	90	33.3	175	140	18	27	539.5	16-1"-8	16388
18"	362	425	51	109	38	175	140	18	30	578	16-1 1/8"-7	21705

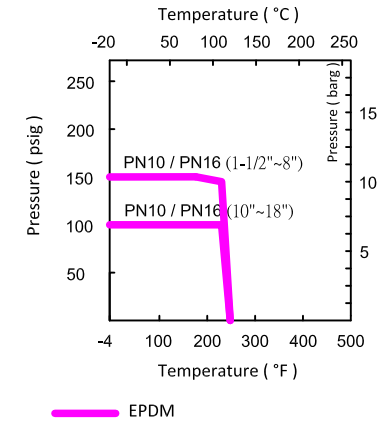

DIE ERSTE INDUSTRY CO., LTD.
TAICHUNG, TAIWAN

SHEET 1 OF 1	DRAWN BY: MICHELLE 2022/8/23	REVIEW BY:	APPROVAL:	UNIT: mm	DO NOT SCALE DRAWING	TITLE: Series 81L(E) DI PTFE CL 150 1.5inch~18inch	REV 2.0
REMARK				PROJECT: 	DWG. NO.		

PROPRIETARY AND CONFIDENTIAL
THE INFORMATION CONTAINED IN THIS DRAWING IS THE SOLE PROPERTY OF «DIE ERSTE INDUSTRY CO., LTD.». ANY REPRODUCTION IN PART OR AS A WHOLE WITHOUT THE WRITTEN PERMISSION OF «DIE ERSTE INDUSTRY CO., LTD.» IS PROHIBITED.